

Forged Brass Ball Valves



F9202 - THREADED END CONNECTION F9222 - SOLDER END CONNECTION

2-PIECE, FORGED BRASS, FULL PORT, THREADED ENDS (1/4" TO 2" WITH CSA/UL/FM APPROVAL) AND SOLDER ENDS, 600 WOG, 150 WSP, VALVES CONFORM TO FEDERAL SPECIFICATION WW-V-35, TYPE II CLASS A, STYLE 3 AND MSS SP-110.



TECHNICAL SUPPORT

Branch:	Phone:
Bridgewater	(902) 543-1068
Cornerbrook	(709) 634-4307
Dartmouth	(902) 468-1650
Moncton	(506) 853-0150
Mount Pearl	(709) 747-7510
New Minas	(902) 681-3961
Oshawa	(905) 436-7366
Sudbury	(705) 675-1266
Timmins	(705) 264-9445
Toronto	(416) 244-5351
Cornwall	(613) 932-1116
Granby	(450) 378-7995
Kingston	(613) 546-0161
Montreal	(514) 766-8541
Ottawa	(613) 745-9135
Pembroke	(613) 732-2857
Sept Iles	(418) 962-9791
Brandon	(204) 728-0104
Regina	(306) 525-1325
Saskatoon	(306) 934-8883
Winnipeg	(204) 786-4411
Cambridge	(519) 621-9440
Hamilton	(905) 547-1951
London	(519) 451-7729
Sarnia	(519) 336-4871
St. Catharines	(905) 684-8196
Windsor	(519) 948-5246
Calgary	(403) 252-7811
Edmonton	(780) 465-8888
Lethbridge	(403) 327-1577
Red Deer	(403) 347-2238
Surrey	(604) 513-9669

CSA/UL/FM APPROVAL

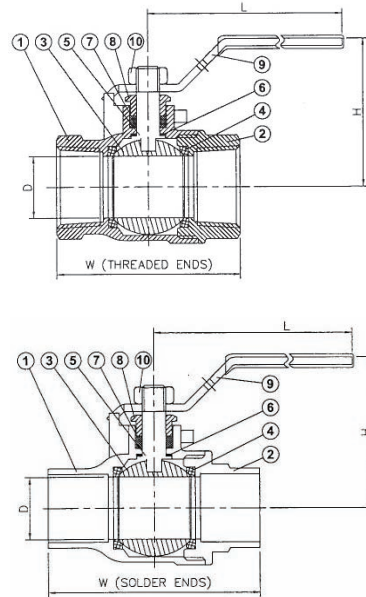

MATERIALS LIST:

NO.	PART	SPECIFICATION
1	BODY	FORGED BRASS C37700 (1/8" - 1-1/2") CAST BRASS C85700 (2"-4")
2	END CAP	FORGED BRASS C37700
3	BALL	BRASS ASTM C85700 OR ASTM C37700
4	SEAT	PTFE
5	STEM	BRASS C36000
6	THRUST WASHER	PTFE
7	PACKING	PTFE
8	GLAND	BRASS C36000
9	HANDLE	ASTM A83 STEEL
10	NUT	AISI-1010

OPTION: (CODE: DESCRIPTION)

- LD: LOCKING HANDLE
- MEM: MEMORY STOP
- EXT: EXTENSION STEM
- S: STAINLESS STEEL

SIZE		D		W				H		L	
				THREADED ENDS		SOLDER ENDS					
IN	MM	IN	MM	IN	MM	IN	MM	IN	MM	IN	MM
1/4"	8	0.40	10	1.81	46	-	-	1.48	37	3.36	84
3/8"	10	0.40	10	1.81	46	-	-	1.48	37	3.36	84
1/2"	15	0.50	12.70	2.04	51	1.93	49	1.56	39	3.36	84
3/4"	20	0.80	20	2.40	60	2.80	70	2.00	50	4.72	118
1"	25	0.98	25	2.92	73	3.36	84	2.16	54	4.72	118
1-1/4"	32	1.28	32	3.36	84	3.84	96	2.64	66	5.36	134
1-1/2"	40	1.50	38	3.68	92	4.36	109	2.8	70	5.36	134
2"	50	1.97	50	4.40	110	5.48	137	3.52	88	8.00	200
2-1/2"	65	2.52	63	5.24	131	6.32	158	3.92	98	8.00	200
3"	80	3.00	75	6.00	150	7.17	182	4.24	106	8.00	200
4"	100	3.00	75	6.56	164	-	-	4.24	106	8.00	200

* STANDARD PORT

Following a policy of continuous improvement, Crane Supply reserves the right to alter any information and specifications in this brochure without prior notice.