

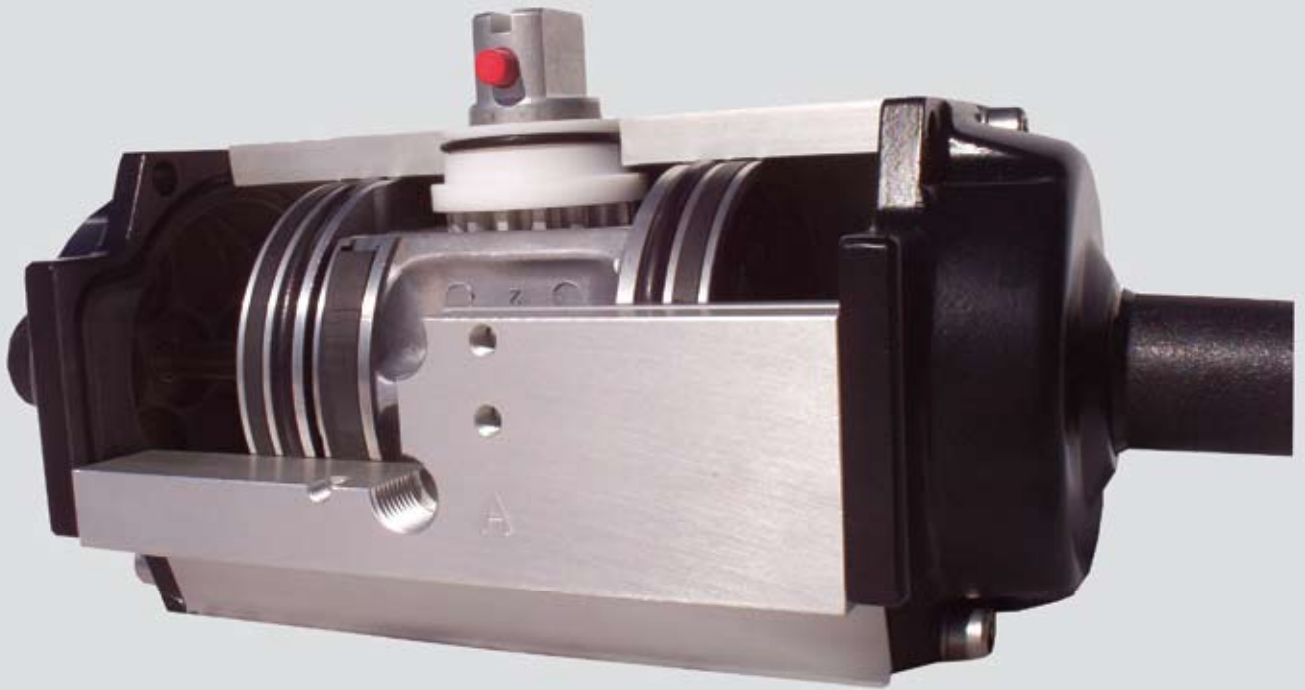

brands you trust.



CRANE® REVO® - Pneumatic Rack and Pinion Actuators

CRANE

Energy Flow Solutions

www.craneenergy.com



Design Features and Benefits

- 1) Standardized actuator to valve interface per DIN ISO 5211 (not visible)
- 2) Standardized accessory interfaces per VDI/VDE 3845 (NAMUR)
- 3) Position indicator per NAMUR standard
- 4) Torque capability exceeding 100,000 in-lbs
- 5) Aluminum body with anodized surfaces for superior corrosion protection inside and out
- 6) Blowout-proof pinion and bushings, no exterior corrosion-susceptible snap rings
- 7) Self-lubricating piston guide bands are positioned to prevent piston movement while providing minimal side friction and higher actuator efficiencies
- 8) Clustered springs are designed for easy and safe conversion (springs not shown)
- 9) Stainless steel end cap fasteners
- 10) Maximized gear tooth engagement
- 11) Large air passages provide for a maximized speed of operation
- 12) Most popular sizes have travel stops in both clockwise and counterclockwise positions as standard
- 13) Complete rebuild capability with soft-part replacement (not visible)

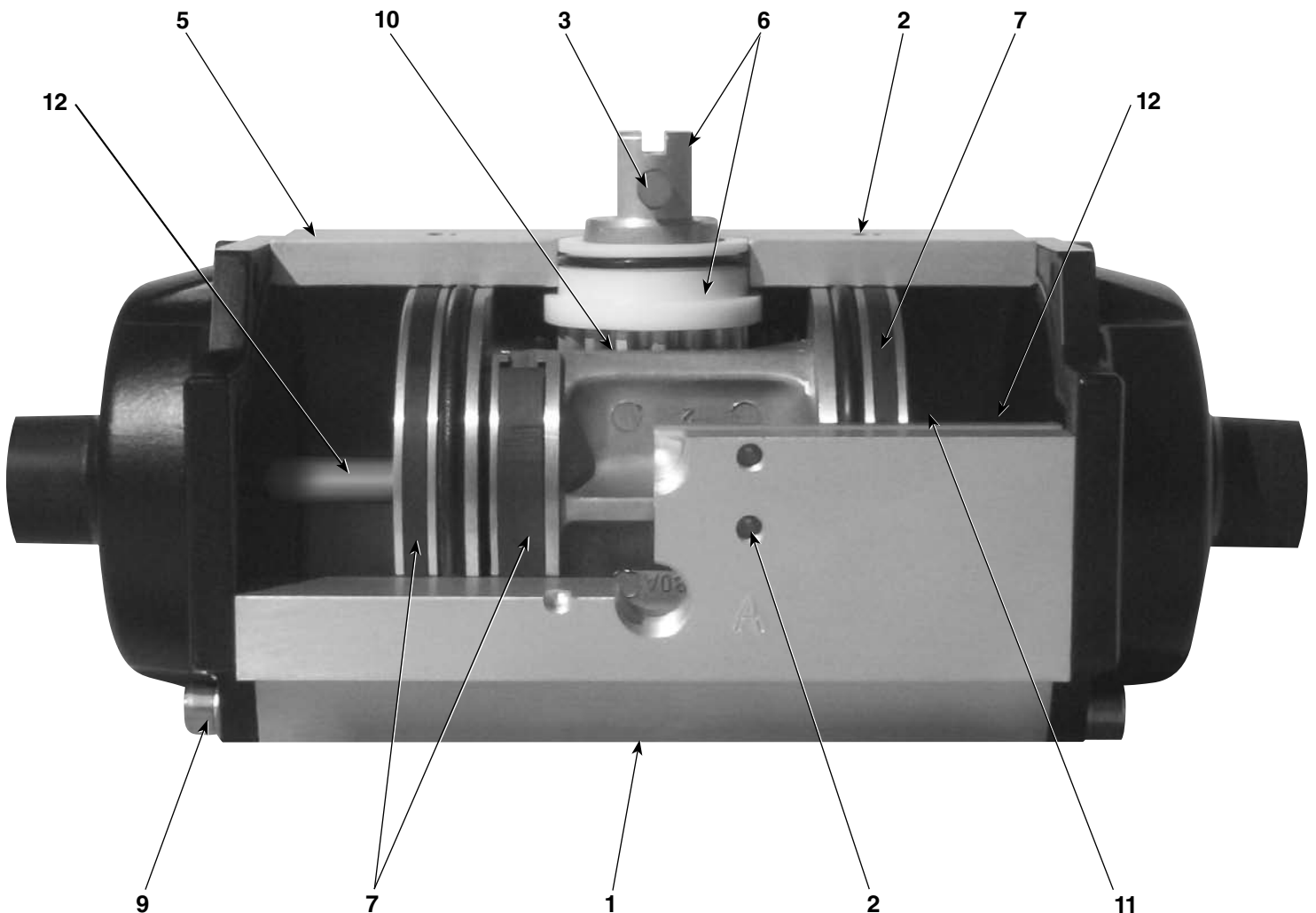



Double Acting Torques

CRANE® REVO® DOUBLE ACTING TORQUE (in-lbs)					
Model	40 psig	60 psig	80 psig	100 psig	120 psig
CRD001	25	37	49	61	N/A*
CRD002	64	96	128	160	N/A*
CRD006	152	227	303	378	N/A*
CRD012	301	451	602	752	903
CRD025	586	878	1171	1464	1757
CRD050	1082	1622	2163	2704	3245
CRD090	2058	3086	4115	5144	6173
CRD130	3131	4697	6263	7828	9394
CRD180	4116	6173	8231	10289	12347
CRD205	6167	9251	12334	15418	18501
CRD380	9256	13883	18511	23139	27767
CRD630	15418	23127	30836	38545	46254
CRD960	23416	35124	46832	58540	70248
CRDH15	35844	53765	71687	89609	107531

Notes:

All torque values are inch-pounds for pressure supply listed.
 Recommended Safety Factor = 10% for double acting actuators.
 * Max Pressure 100 psig.

CRANE® REVO® SPRING RETURN TORQUE (in-lbs)													
	Spring Quantity	Spring		40 psig		60 psig		80 psig		100 psig		120 psig	
		Start	End	Start	End	Start	End	Start	End	Start	End	Start	End
CRS/CRA002	02	18	9	56	47	88	79	120	111	152	143	N/A*	N/A*
	04	35	18	47	30	79	62	111	94	143	126	N/A*	N/A*
	06	53	26			71	49	103	76	135	108	N/A*	N/A*
	08	69	34			63	27	95	59	127	91	N/A*	N/A*
	10	87	43					86	42	118	74	N/A*	N/A*
	12	104	52					77	25	109	57	N/A*	N/A*
CRS/CRA006	02	39	20	132	113	208	188	283	264	359	340	N/A*	N/A*
	04	78	39	113	74	188	149	264	225	340	301	N/A*	N/A*
	06	121	61			167	107	243	182	318	258	N/A*	N/A*
	08	162	81			147	66	222	142	298	217	N/A*	N/A*
	10	200	100					203	103	278	178	N/A*	N/A*
	12	239	120					183	64	259	140	N/A*	N/A*
CRS/CRA012	02	73	36	265	228	415	379	565	529	716	680	866	830
	04	145	73	228	156	379	306	529	457	680	607	830	757
	06	218	109	192	83	342	234	493	384	643	534	794	685
	08	290	145			306	161	457	311	607	462	757	612
	10	363	181			207	88	420	239	571	389	721	540
	12	435	218					384	166	534	317	685	467
CRS/CRA025	02	142	71	515	444	808	737	1100	1030	1393	1322	1686	1615
	04	283	142	444	302	737	595	1030	888	1322	1181	1615	1474
	06	425	212	373	161	666	454	959	746	1252	1039	1544	1332
	08	566	283			595	312	888	605	1181	898	1474	1190
	10	708	354			524	170	817	463	1110	756	1403	1049
	12	850	425					746	322	1039	614	1332	907
CRS/CRA050	02	259	130	952	822	1493	1363	2034	1904	2574	2445	3115	2985
	04	519	259	822	563	1363	1104	1904	1644	2445	2185	2985	2726
	06	778	389	692	303	1233	844	1774	1385	2315	1926	2856	2467
	08	1038	519			1104	585	1644	1125	2185	1666	2726	2207
	10	1297	649			974	325	1515	866	2055	1407	2596	1948
	12	1557	778					1385	606	1926	1147	2467	1688
14	1816	908					1255	347	1796	888	2337	1429	

Notes:

All torque values are inch-pounds for pressure supply listed.
 Torque values are the same for both Spring Fail Clockwise, FCW (REVO® style S) and Counterclockwise, FCCW (REVO® style A).
 Recommended Safety Factor = 20% for single acting actuators.
 * Max Pressure 100 psig.



Spring Return Torques

CRANE® REVO® SPRING RETURN TORQUE (in-lbs) continued

	Spring Quantity	Spring		40 psig		60 psig		80 psig		100 psig		120 psig	
		Start	End	Start	End	Start	End	Start	End	Start	End	Start	End
CRS/CRA090	02	474	237	1820	1583	2849	2612	3878	3641	4907	4670	5936	5699
	04	949	474	1583	1109	2612	2138	3641	3167	4670	4195	5699	5224
	06	1423	712	1346	635	2375	1663	3404	2692	4433	3721	5461	4750
	08	1897	949			2138	1189	3167	2218	4195	3247	5224	4276
	10	2372	1186			1901	715	2929	1744	3958	2772	4987	3801
	12	2846	1423					2692	1269	3721	2298	4750	3327
	14	3321	1660					2455	795	3484	1824	4513	2852
CRS/CRA130	02	719	359	2772	2413	4338	3978	5903	5544	7469	7110	9034	8675
	04	1437	719	2413	1694	3978	3260	5544	4825	7110	6391	8675	7957
	06	2156	1078	2053	975	3619	2541	5185	4107	6750	5672	8316	7238
	08	2847	1437			3260	1822	4825	3388	6391	4954	7957	6519
	10	3593	1797			2900	1104	4466	2669	6032	4235	7597	5801
	12	4312	2156					4107	1951	5672	3516	7238	5082
	14	5030	2515					3747	1232	5313	2798	6879	4363
CRS/CRA180	02	945	473	3643	3170	5701	5228	7759	7286	9816	9344	11874	11401
	04	1890	945	3170	2225	5228	4283	7286	6341	9344	8399	11401	10456
	06	2836	1418	2698	1280	4756	3338	6813	5396	8871	7453	10929	9511
	08	3781	1890			4283	2393	6341	4450	8399	6508	10456	8566
	10	4726	2363			3810	1447	5868	3505	7926	5563	9984	7621
	12	5671	2836					5396	2560	7453	4618	9511	6676
	14	6616	3308					4923	1615	6981	3673	9039	5730
CRS/CRA205	02	1490	745	5422	4677	8505	7760	11589	10844	14673	13927	17756	17011
	04	2981	1490	4677	3186	7760	6270	10844	9354	13927	12437	17011	15521
	06	4471	2236	3932	1696	7015	4780	10099	7863	13182	10947	16266	14030
	08	5961	2981			6270	3289	9354	6373	12437	9456	15521	12540
	10	7452	3726			5525	1799	8608	4883	11692	7966	14775	11050
	12	8942	4471					7863	3392	10947	6476	14030	9559
	14	10432	5216					7118	1902	10202	4985	13285	8069
CRS/CRA380	02	2237	1119	8137	7018	12765	11646	17393	16274	22020	20902	26648	25530
	04	4475	2237	7018	4781	11646	9409	16274	14037	20902	18665	25530	23292
	06	6712	3356	5900	2544	10528	7172	15155	11799	19783	16427	24411	21055
	08	8949	4475			9409	4934	14037	9562	18665	14190	23292	18818
	10	11186	5593			8290	2697	12918	7325	17546	11953	22174	16581
	12	13424	6712					11799	5088	16427	9715	21055	14343
	14	15661	7830					10681	2850	15309	7478	19936	12106
CRS/CRA630	02	3728	1864	13554	11690	21263	19400	28972	27109	36681	34818	44391	42527
	04	7455	3728	11690	7963	19400	15672	27109	23381	34818	31090	42527	38799
	06	11183	5591	9827	4235	17536	11944	25245	19653	32954	27362	40663	35071
	08	14910	7455			15672	8217	23381	15926	31090	23635	38799	31344
	10	18638	9319			13808	4489	21517	12198	29226	19907	36935	27616
	12	22366	11183					19653	8471	27362	16180	35071	23889
	14	26093	13047					17790	4743	25499	12452	33208	20161
CRS/CRA960	03	5591	2796	20620	17825	32328	29532	44036	41240	55744	52948	67452	64656
	06	11183	5591	17825	12233	29532	23941	41240	35649	52948	47357	64656	59065
	09	16774	8387	15029	6642	26737	18350	38445	30058	50153	41766	61861	53474
	12	22366	11183			23941	12758	35649	24466	47357	36174	59065	47882
	15	27957	13979			21145	7167	32853	18875	44561	30583	56269	42291
	18	33549	16774					30058	13283	41766	24991	53474	36699
CRS/CRAH15	02	8663	4331	31512	27181	49434	45103	67356	63024	85278	80946	103199	98868
	04	17325	8663	27181	18518	45103	36440	63024	54362	80946	72284	98868	90205
	06	25988	12994	22849	9855	40771	27777	58693	45699	76615	63621	94537	81543
	08	34651	17325			36440	19114	54362	37036	72284	54958	90205	72880
	10	43314	21657			32109	10452	50030	28374	67952	46295	85874	64217
	12	51976	25988					45699	19711	63621	37633	81543	55554
	14	60639	30320					41368	11048	59289	28970	77211	46892

Notes: All torque values are inch-pounds for pressure supply listed. Torque values are the same for both Spring Fail Clockwise, FCW (REVO® style S) and Counterclockwise, FCC (REVO® style A). Recommended Safety Factor = 20% for single acting actuators.

Dimensions

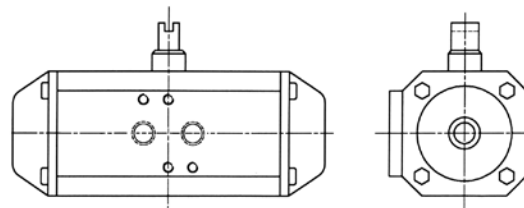
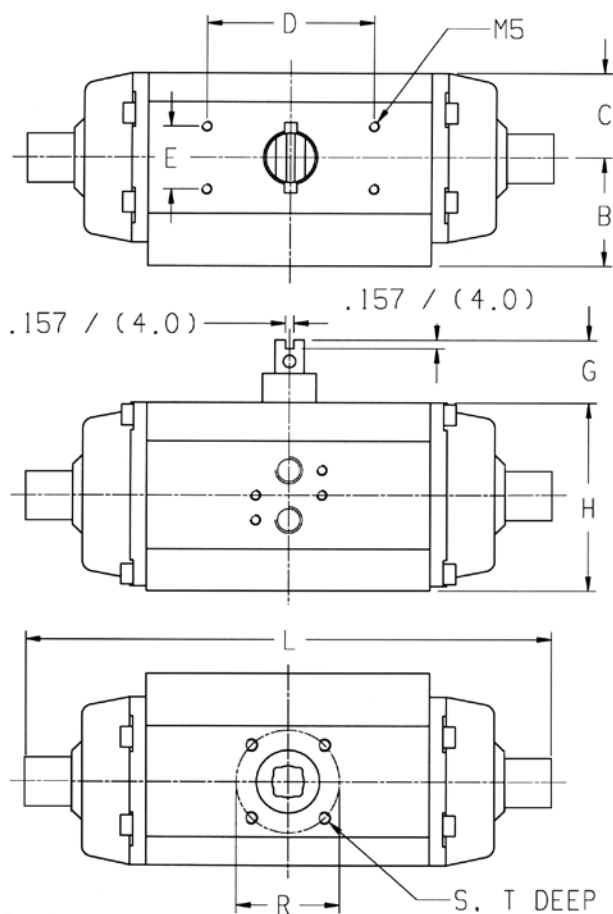

Sizes CRD001, CRS002 and CRS006

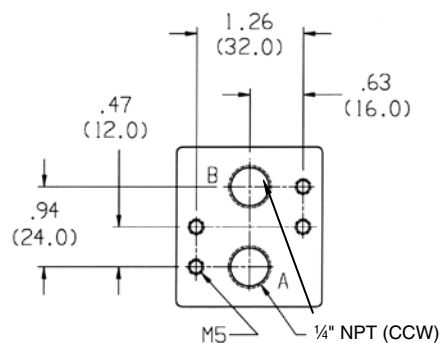

Dimensions are in inches and millimeters. Dimensions are nominal. For certified drawings, please contact factory.

DIMENSION CHART, REVO® CRD001-CRS/CRA180 RACK & PINION ACTUATORS

Size	Units	L	G	H	B	C	D	E	R	S	T	ISO	SQ
CRD001	Inches mm	3.62 92	0.79 20	1.77 45	1.79 45.5	0.81 20.5	1.97 50	0.98 25	1.42 36	M5	0.28 7	F03	0.35 9
CRS002/ CRA002	Inches mm	5.59 142	0.79 20	2.15 54.5	1.89 48	1.00 25.4	1.97 50	0.98 25	1.65 42	M5	0.31 8	F04	0.43 11
CRS006/ CRA006	Inches mm	6.81 173	0.79 20	2.93 74.5	2.22 56.5	1.36 34.5	3.15 80	1.18 30	1.97 50	M6	0.39 10	F05	0.55 14
CRS012/ CRA012	Inches mm	10.43 265	0.79 20	3.58 91	2.66 67.5	1.61 41	3.15 80	1.18 30	1.97 50	M6	0.35 9	F05	0.55 14
CRS025/ CRA025	Inches mm	11.42 290	0.79 20	4.76 121	3.23 82	2.17 55	3.15 80	1.18 30	1.97 50	M6	0.35 9	F05	0.55 14
CRS050/ CRA050	Inches mm	14.37 365	0.79 20	5.75 146	3.70 94	2.64 67	3.15 80	1.18 30	2.76 70	M8	0.49 12.5	F07	0.67 17
CRS090/ CRA090	Inches mm	17.72 450	1.18 30	6.54 166	4.29 109	3.07 78	5.12 130	1.18 30	4.02 102	M10	0.63 16	F10	0.87 22
CRS130/ CRA130	Inches mm	20.67 525	1.18 30	7.56 192	4.53 115	3.54 90	5.12 130	1.18 30	4.92 125	M12	0.71 18	F12	1.06 27
CRS180/ CRA180	Inches mm	21.06 535	1.18 30	8.58 218	5.08 129	4.02 102	5.12 130	1.18 30	4.92 125	M12	0.71 18	F12	1.06 27



Dimensions

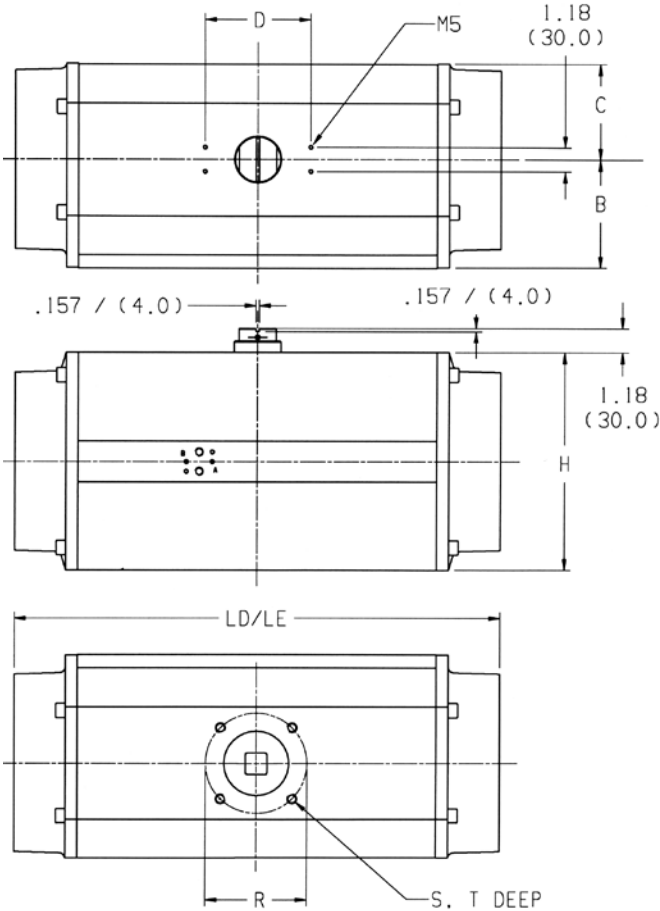

**Actuator / Valve ISO F25
8 Hole Mounting Pattern**
 Mfg. Bolt Circle: 10.00" (254)
 Mfg. Bolt Hole: M16
 Mfg. Bolt Hole Depth: 0.98" (25)
 (CRS960 has 2 ISO Patterns)

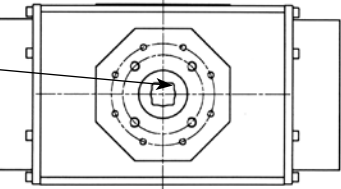

**Actuator / Valve ISO F30
8 Hole Mounting Pattern**
 Mfg. Bolt Circle: 11.73" (298)
 Mfg. Bolt Hole: M16
 Mfg. Bolt Hole Depth: 0.98" (25)
 (CRSH15 has 2 ISO Patterns)

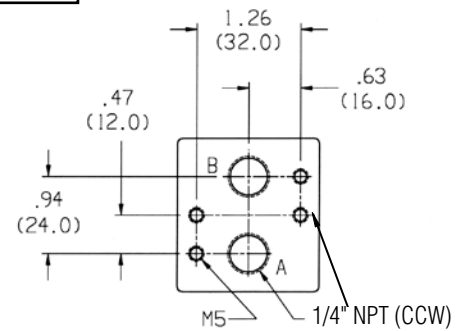
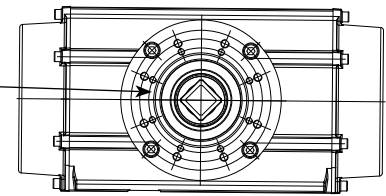

Dimensions are in inches and millimeters. Dimensions are nominal. For certified drawings, please contact factory.

DIMENSION CHART, REVO® CRS/CRA205-CRS/CRAH15 RACK & PINION ACTUATORS

Size	Units	LD	LE	H	B	C	D	R	S	T	ISO	SQ
CRS205/ CRA205	Inches mm	15.35 390	19.29 490	10.79 274	5.51 140	5.35 136	5.12 130	5.51 140	M16	1.06 26	F14	1.42 36
CRS380/ CRA380	Inches mm	19.69 500	23.62 600	11.18 284	5.51 140	5.35 136	5.12 130	6.50 165	M16	1.02/1.18 26/30	F14/F16	1.42/1.81 36/46
CRS630/ CRA630	Inches mm	21.26 540	29.13 740	13.54 344	6.96 177	6.88 175	5.12 130	6.50 165	M20	.86 22	F16	1.81 46
CRS960/ CRA960	Inches mm	22.24 565	30.70 780	16.54 420	8.26 210	8.26 210	5.91 150	6.50/10.00 165/254	M20/M16	.98 25	F16*/F25	1.81/2.17 46/55
CRSH15/ CRAH15	Inches mm	28.66 728	35.03 890	17.72 450	8.79 223.5	8.79 223.5	6.89 175	10.00/11.73 254/298	M16/M20	.98 25	F25/F30	2.17/2.95 55/75

LD Length of Double-acting Actuator

LE Length of Spring Return Actuator

* This Model also has ISO F25 Mounting Pattern

Materials of Construction

Double Acting: CRD001, CRD002 & CRD006		
Item	Description	Material
1	Body	Aluminum Alloy, Extruded
2	Piston	POM
3	Shaft	Aluminum / Anodized
4	Right End Cap	Aluminum
5	Left End Cap	Aluminum
6	Screw	Stainless Steel
7	Washer	Stainless Steel
8	Indicator	Polyamide
9	O-ring - Piston Stainless Steel	NBR
10	O-ring - Shaft	NBR
11	O-ring - End Cap	NBR
12	Bearing	PTFE, Carbon-filled
13	Insert	Aluminum / Anodized
↓ Spring Return Parts ↓		Models CRS/CRA002 & CRS/CRA006
14	Spring - Outer	CrSi Alloy / Coated
15	Spring - Inner	CrSi Alloy / Coated

Double Acting: CRD205 through CRDH15		
Item	Description	Material
1	Body	Aluminum / Painted
2	Piston	Aluminum / St50K (Gear Teeth)
3	Shaft	Aluminum / Anodized
4	DA End Cap	Aluminum / Painted
5-7	Bearing	POM
8	Retaining Ring	Spring Steel
9-10	Piston Bearing	PTFE, Carbon-filled
11	O-ring - Piston	NBR
12	O-ring - End Cap	NBR
13	O-ring	NBR
14	O-ring - Shaft	NBR
15	Screw	Stainless Steel
16	Washer	Stainless Steel
17	Indicator	Polyamide
↓ Spring Return Parts ↓		Models CRS/CRA205 - CRS/CRAH15
18	SR End Cap	Aluminum / Painted
19	Spring - CW Wound	CrSi Alloy / Coated
20	Spring - CCW Wound	CrSi Alloy / Coated

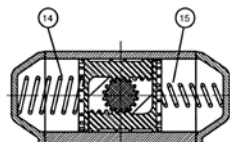
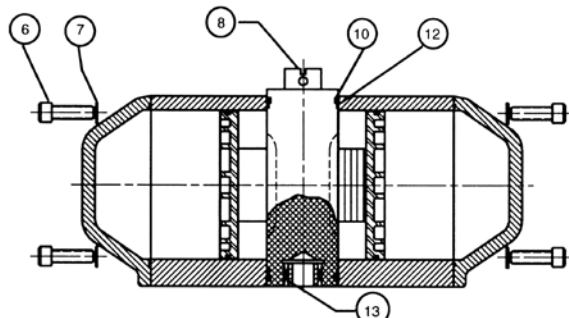
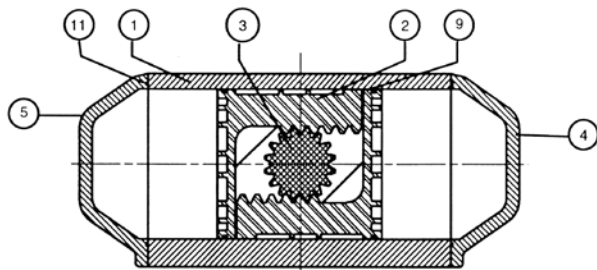

Spring Return: CRS002 & CRS006 Only

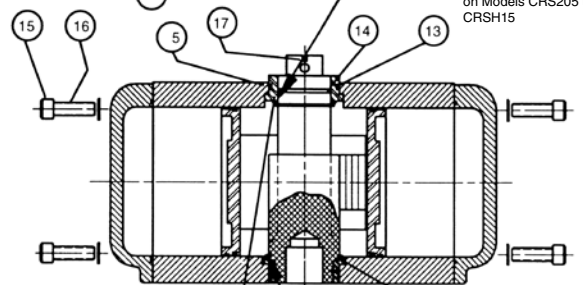
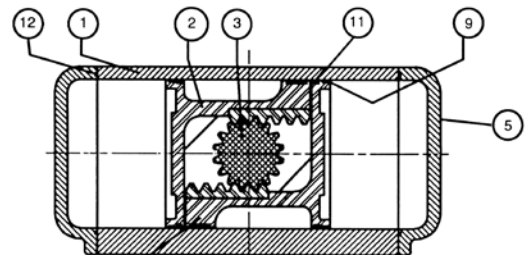

Top Retaining Ring & Bearing on Models CRS205 through CRSH15

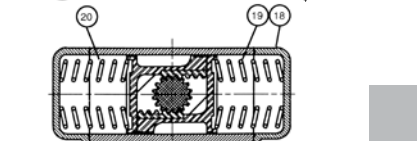

Bottom Retaining Ring & Bearing on Model CRS205 only

Spring Return: CRS205 through CRSH15

Materials of Construction

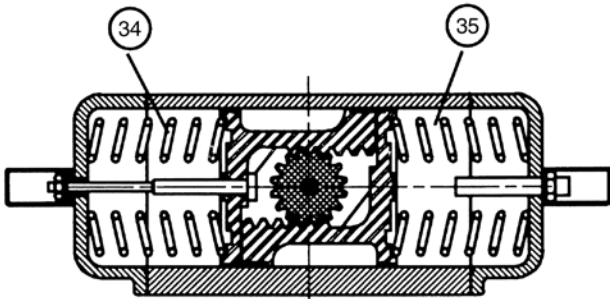
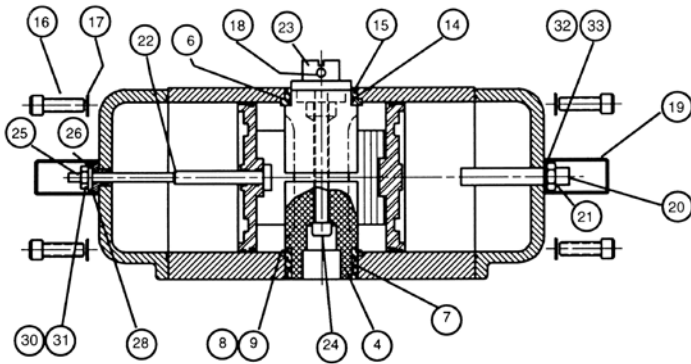
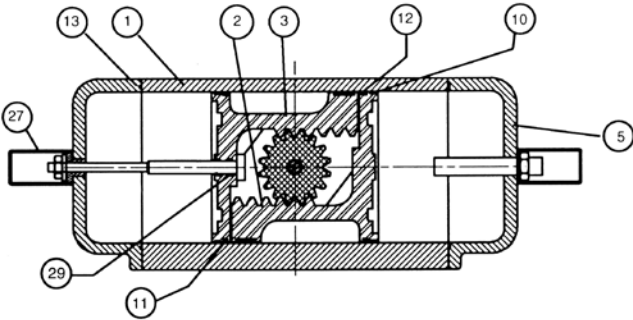

Spring Return: CRS/CRA012 through CRS/CRA180

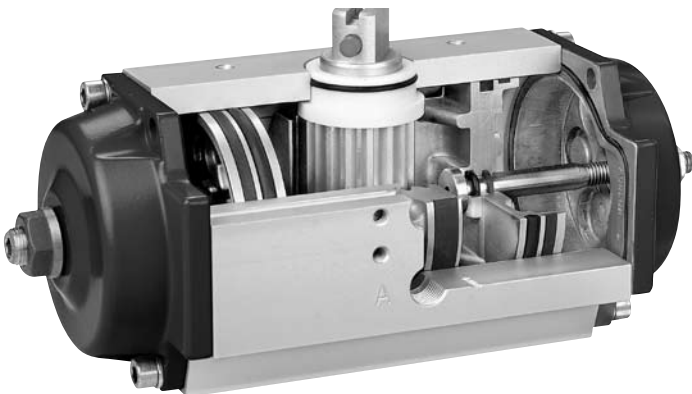

Double Acting: CRD012 through CRD180		
Item	Description	Material
1	Body	Aluminum / Anodized
2	Piston "Open"	Aluminum
3	Piston "Closed"	Aluminum
4	Shaft	Aluminum / Anodized
5	End Cap	Aluminum / Painted
6-8	Bearing	POM
9	Retaining Ring	Spring Steel
10	Piston Bearing	PTFE, Carbon-filled
11	Piston Bearing	PTFE, Carbon-filled
12	O-ring - Piston	NBR
13	O-ring - End Cap	NBR
14	O-ring - Shaft	NBR
15	O-ring	NBR
16	Screw	Stainless Steel
17	Washer	Stainless Steel
18	Indicator	Polyamide
19	Protective Cap	Polyethylene
20	"Open" Stop Screw	Steel / Zinc-plated
21	Sealing Nut	Steel / Zinc-plated
22	"Closed" Stop Screw	Stainless Steel
23	Shaft - Top	Aluminum / Anodized
24	Shaft Screw	Steel / Zinc-plated
25	Sealing Nut	Steel / Zinc-plated
26	Threaded Insert	Stainless Steel
27	Protective Cap	Polyethylene
28	O-ring	NBR
29	Stop Screw O-ring	NBR
30	Washer	POM
31-32	O-ring	NBR
33	Washer	POM

↓ Spring Return Parts



Models CRS/CRA012 - CRS/CRA180

34	Spring - CW Wound	CrSi Alloy / Coated
35	Spring - CCW Wound	CrSi Alloy / Coated

Configurations and Specifications

CRANE® REVO® STANDARD MOUNTING CONFIGURATIONS						OPTIONAL MOUNTING CONFIGURATIONS				
REVO® Model	ISO Pattern	Mounting Configuration (bolt circle)	Metric Bolting	NAMUR, WxLxH (mm)	Optional Port (mm)	ISO Pattern	Order Code	Mounting Config. (bolt circle)	Metric Bolting	Optional Port (mm)
CD001	F03	F03/V9 (36)	M5x4	25x50x15 ¹	25			(N/A)		
CR_002	F04	F04/V11 (42)	M5x4	25x50x20 ¹	30	F03	A1	F03/V9 (36)	M5x4	25
CR_006	F05	F05/V14 (50)	M6x4	30x80x20	35	F04	B1	F04/V11 (42)	M5x4	30
CR_012	F05	F05/V14 (50)	M6x4	30x80x20	35			(N/A)		
CR_025	F05	F05/V14 (50)	M6x4	30x80x20	35			(N/A)		
CR_050	F07	F07/V17 (70)	M8x4	30x80x20 + 30x130x20	55			(N/A)		
CR_090	F10	F10/V22 (102)	M10x4	30x130x30	70	F07	D1	F07/V17 (70)	M8x4	55
CR_130	F12	F12/V27 (125)	M12x4	30x130x30	85	F10	E1	F10/V22 (102)	M10x4	70
CR_180	F12	F12/V27 (125)	M12x4	30x130x30	85			(N/A)		
CR_205	F14	F14/V36 (140)	M16x4	30x130x30	100	F12	F1	F12/V27 (125)	M12x4	85
CR_380	F14	F14/V36 (140)	M16x4	30x130x30	100	F14	G1	F14/R45 ¹ (140)	M16x4	100
CR_630	F16	F16/V46 (165)	M20x4	30x130 ¹ x30	130	F12	F1	F12/V27 (125)	M12x4	85
CR_960	F16 ²	F16/V46 (165) +F25/V46 (254) (CR_960 is standard with two mounting bolt circles)	M20x4 M16x8	30x150 ¹ x30	130	F14	G1	F14/R45 ¹ (140)	M16x4	100
CR_H15	F25	F25/V55 (254)	M16x8	30x175 ¹ x30	130 ¹	F14	G2	F14/V36 (140)	M16x4	100
						F16	H1	F16/R70 ¹ (165)	M20x4	130
						F25 ²	J4	F25/V55 (254) +F16/V55 (165)	M16x8 M20x4	130 ¹
						F30	K1	F30/V75 (298)	M20x8	130 ¹

Notes: 1) Indicates that this dimension is a non-standard ISO or NAMUR dimension for that particular pattern.
 2) Standard and Optional configuration includes two mounting bolt circles.
 3) V = Square, R = Round

4) __ = Function;
 D = Double Acting, S = Spring to Close,
 A = Spring to Open

CRANE® REVO® SPECIFICATIONS											
REVO® Model	Weight in lbs (kg)		Air Connection Size	Travel Range		Adjustability		Operating Pressure Range in psi (bar)		Operating Temperature Range	
	DA	SR		NPT	Max	Min	Pos 1	Pos 2	Min	Max	Min
CD001	0.7 (0.3)	N/A	1/4"	90°	74°	0°	82° to 90°	36	145	-4°F (-20°C)	176°F (80°C)
CR_002	1.10 (0.5)	1.10 (0.5)						(2.5)	(10)		
CR_006	2.09 (.95)	2.20 (1.0)									
CR_012	4.9 (2.2)	5.07 (2.3)	1/4"	98°	74°	-4° to 8°	82° to 94°	29 (2)	145 (10)		
CR_025	7.7 (3.5)	8.4 (3.8)									
CR_050	13.0 (5.9)	14.66 (6.7)									
CR_090	22.9 (10.4)	26.9 (12.2)									
CR_130	41.9 (19.0)	46.29 (21.0)									
CR_180	49.6 (22.5)	55.77 (25.3)									
CR_205	66.2 (30.0)	72.75 (33.0)									
CR_380	76.05 (34.5)	85.97 (39.0)	90°	0°	90°						
CR_630	99.20 (45.0)	119.04 (54.0)									
CR_960	138.88 (63.0)	164.20 (74.5)									
CR_H15	168.43 (76.4)	199.29 (90.4)									



Accessories and Product Overview

CCR Series – Economical – General Purpose

- Engineered resin housing
- 3D position indicator
- Designed for use in NEMA 4, 4x environments
- General purpose and intrinsically safe options
- Mechanical or inductive switches

CCA Series – Conventional w/Multiple Options

- Epoxy-coated aluminum or stainless steel housing
- 3D, Disk, or no position indication
- NEMA 4, 4x, Class I Division 2, and intrinsically safe
- Mechanical, proximity, or inductive switches
- World's first wireless option
- Three position dribble control option
- Four to 20 mA feedback transmitter option
- **A**ctuator **S**ensor interface option



CXA Series – Explosion Proof

- Epoxy-coated aluminum housing
- 3D position indicator
- NEMA 4, 4x, 7, and 9
- Non-incentive and intrinsically safe options
- Mechanical, proximity, or inductive switches
- Three position dribble control option
- Four to 20 mA feedback transmitter option
- **A**ctuator **S**ensor interface option



C100 Series – Positioners for REVO®

- Single cast aluminum housing for all types
 - Pneumatic (C100P)
 - Electro-pneumatic (C100E)
 - Explosion proof (C100EX)
- Powder-polyester coated housing
- Stainless steel, retained fasteners
- NEMA 4x and IP66 protection
- Available drives: NAMUR, 1/2" square and others
- Maintenance-friendly pilot valve
- Simple calibration – external zero adjustment

Solenoids

Any manufacturer's solenoid can be mounted. Please provide the model number when ordering.

CRANE® Sizing Program REVO® Pneumatic Actuators



- Build Projects
- Quote Projects

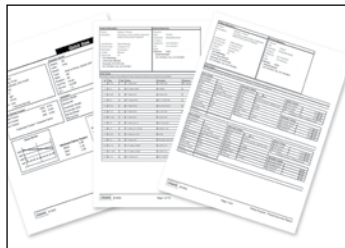

- Quick Actuator Sizing
- ISA Style Data Sheets
- Multiple Valve Sizing

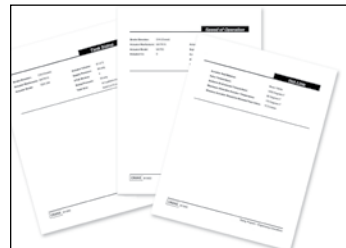

Common Engineering Performance Calculations

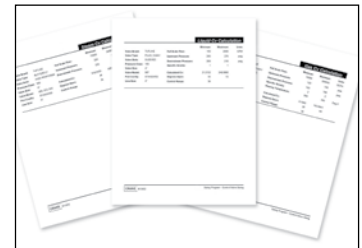

Simplified Valve Flow Sizing for Liquids, Gasses, Steam

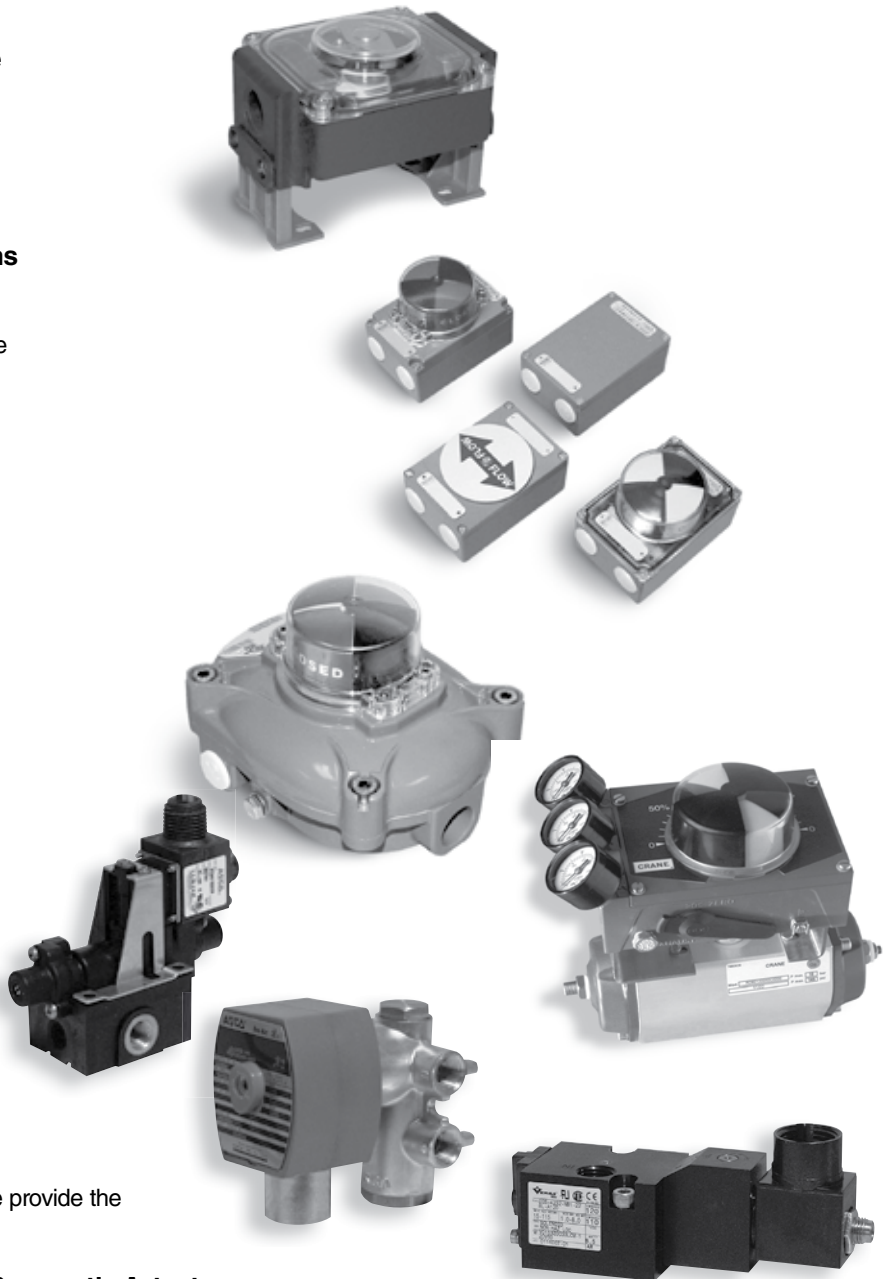

How to Specify

Standard Actuator Configurations Part Number

C R **D** **0 1 2** **0 0** **B**

Series

CR REVO® Actuator

Function

- D** Double Acting
- S** Spring to Close
- A** Spring to Open

Size

- 001**
- 002**
- 006**
- 012**
- 025**
- :**
- H15**

Refer to Tech. Data Sheets

Number of Springs

- 00** Double Acting
- 01** Spring Return, 1 Spring
- 02** Spring Return, 2 Springs
- 03** Spring Return, 3 Springs
- :**
- 09** Spring Return, 9 Springs
- 10** Spring Return, 10 Springs

Travel Stops

- A** Single Travel Stops (Models 001-006)
- B** Dual Travel Stops (Model 012-180)
- C** No Travel Stops (Model 205-H15)
- D** External Dual Travel Stops (Model 205-H15)

Note: Version B has overtravel (4° off set in pinion and 4° in piston) and limit stops.

Special Actuator Configurations Part Number

00 **00** **0**

Miscellaneous

- 0** Standard
- X** Specials

Surface Protection

- 00** with Black Glossy End Caps (RAL 9005)

Temperature

- 00** Standard Nitrile Seals (Buna-N Rubber)
- LB** Low Temperature Seals (EPDM)
- HB** High Temp Seals (Viton®)

PRODUCT RESPONSIBILITY

CRANE's concern for product performance extends to the product's period of service. We feel it is important for users to also be aware of their responsibilities. Our products are manufactured and used in numerous applications with a wide variety of service conditions. While general guidelines are often furnished, it is not possible to provide complete and specific performance data for every conceivable service condition. Therefore, the end user must assume final responsibility for proper evaluation, application, and performance of all products. The contents of this document are presented for information purposes only. Every effort has been made to ensure accuracy.

This information is not intended to be construed as warranties or guarantees, expressed or implied, nor imply use applicability, for products or services described herein. We reserve the right to modify or improve the designs and specifications of such products at any time without notice. As the manufacturer, CRANE sells its products and services pursuant to its standard terms and conditions of sale, including its limited warranty, copies of which are available upon request. CRANE limits its liability specifically to the replacement or repair of defective items, or to a refund for same. CRANE does not accept liability for any incidental or consequential damages.



CRANE Energy Flow Solutions®

CRANE Energy Global Headquarters
4526 Research Forest Drive, Suite 400
The Woodlands, Texas 77381 U.S.A.
Tel.: (1) 936-271-6500
Fax.: (1) 936-271-6510

CRANE REVO Customer Service
3671 New Town Boulevard
St. Charles, Missouri 63301
Tel.: (1) 636-688-8750
Fax.: (1) 636-688-8755

www.craneenergy.com



Energy Flow Solutions



brands you trust.



COMPAC-NOZ®



DUO-CHEK®



NOZ-CHEK®



STOCKHAM®



UNI-CHEK®

NUCLEAR

VALVE SERVICES

EG-RV-CT-EN-L16-20-1110 (CV-204)

Crane Co., and its subsidiaries cannot accept responsibility for possible errors in catalogues, brochures, other printed materials, and website information. Crane Co. reserves the right to alter its products without notice, including products already on order provided that such alteration can be made without changes being necessary in specifications already agreed. All trademarks in this material are property of the Crane Co. or its subsidiaries. The Crane and Crane brands logotype (Aloyco®, Center Line®, Compac-Noz®, Crane®, Duo-Chek®, Flowseal®, Jenkins®, Krombach®, Noz-Chek®, PacificValves®, Stockham®, Triangle®, Uni-Chek®) are registered trademarks of Crane Co. All rights reserved.